



**SUBARU**

PART NUMBER: E361SXA600

**INSTALLATION  
INSTRUCTIONS**

DESCRIPTION: TRIBECA CROSSBAR KIT

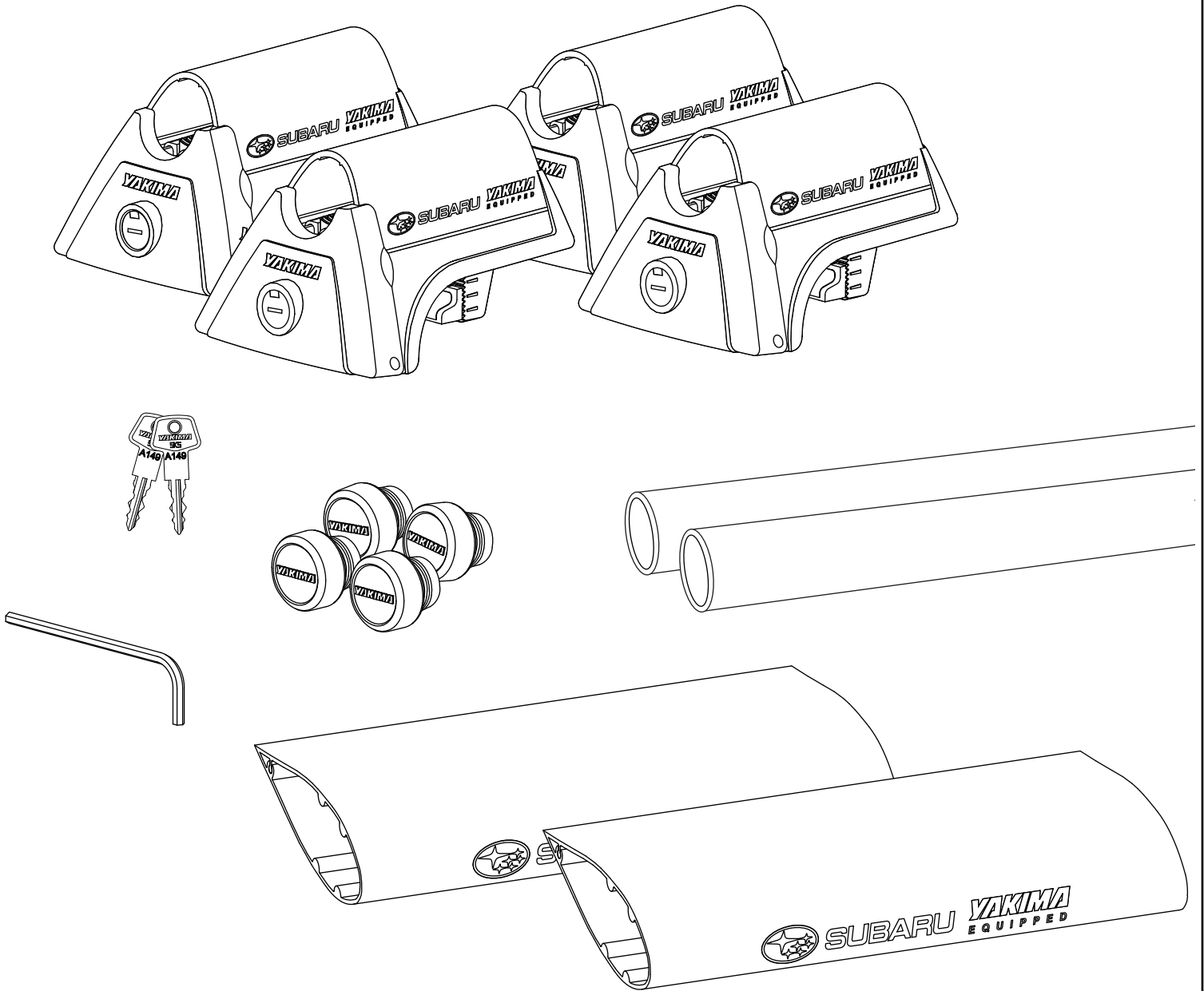

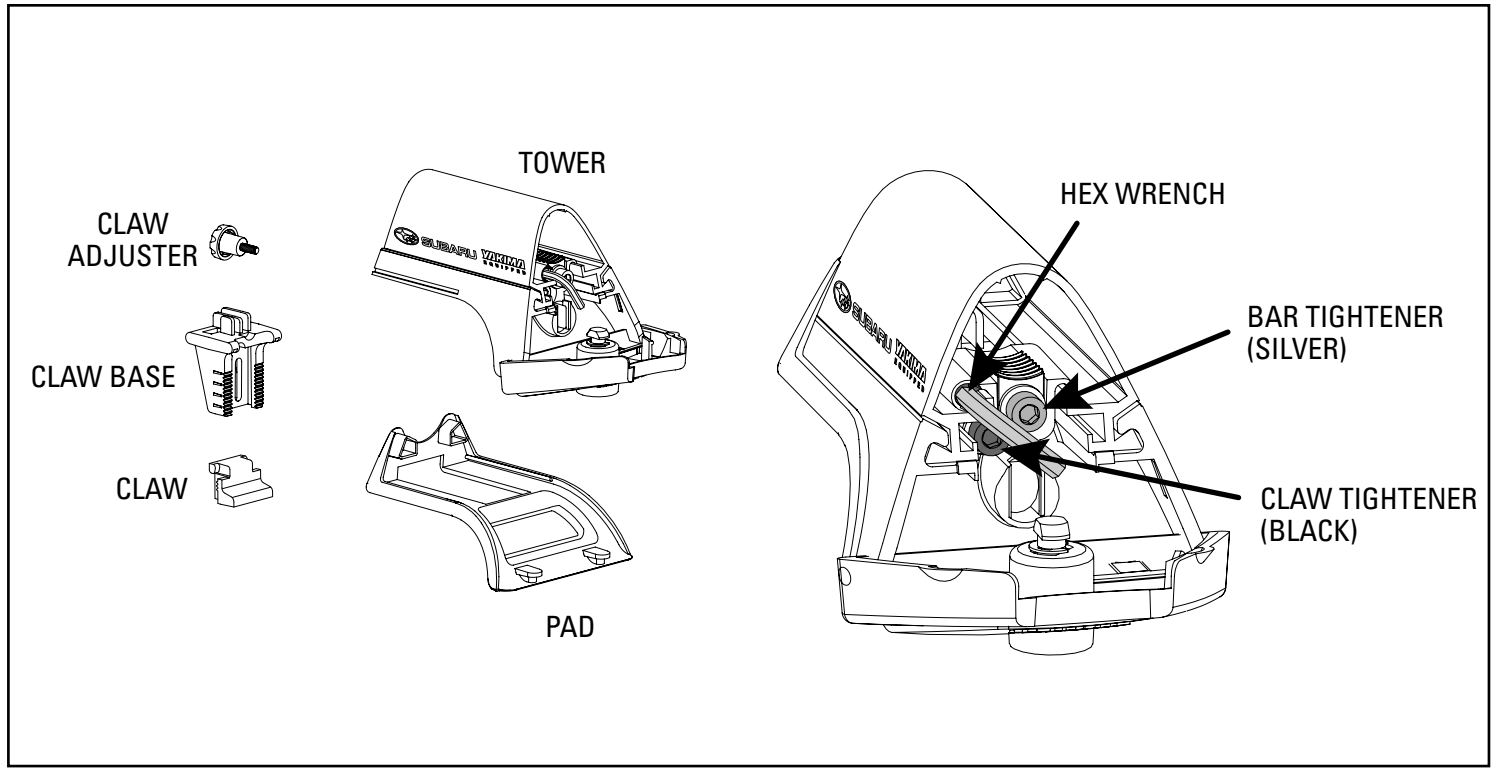
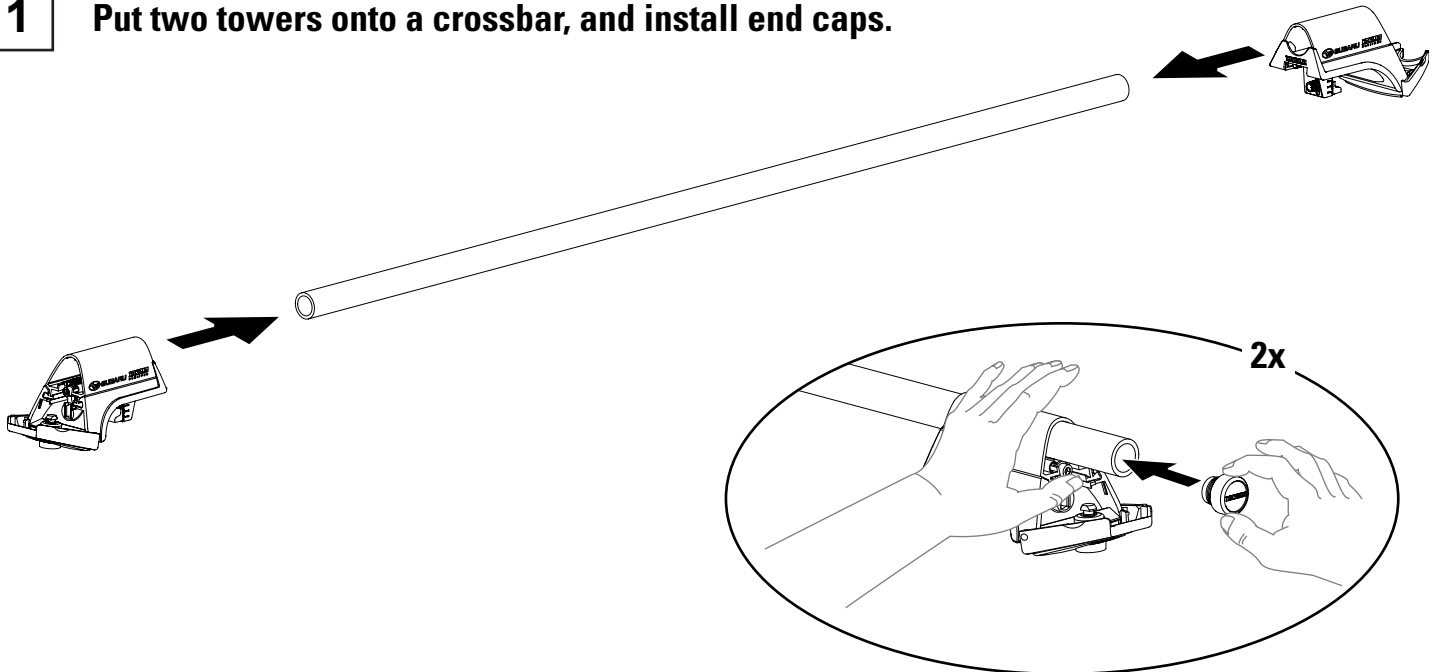
**1 Put two towers onto a crossbar, and install end caps.**

**NOTE:** If necessary, loosen the silver bar tightener a couple turns using the integrated assembly device.

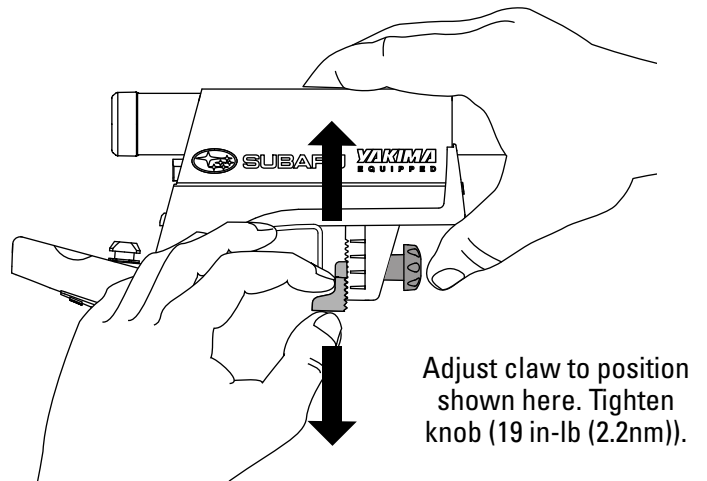
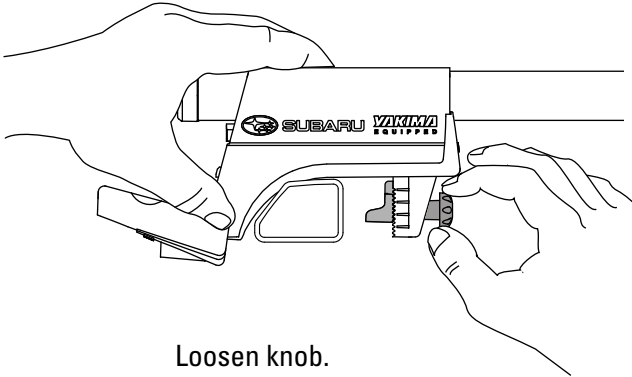
**2 Adjust the claw vertically.****3 Put towers and bar onto rack.**

Position front towers an equal distance from front of car.

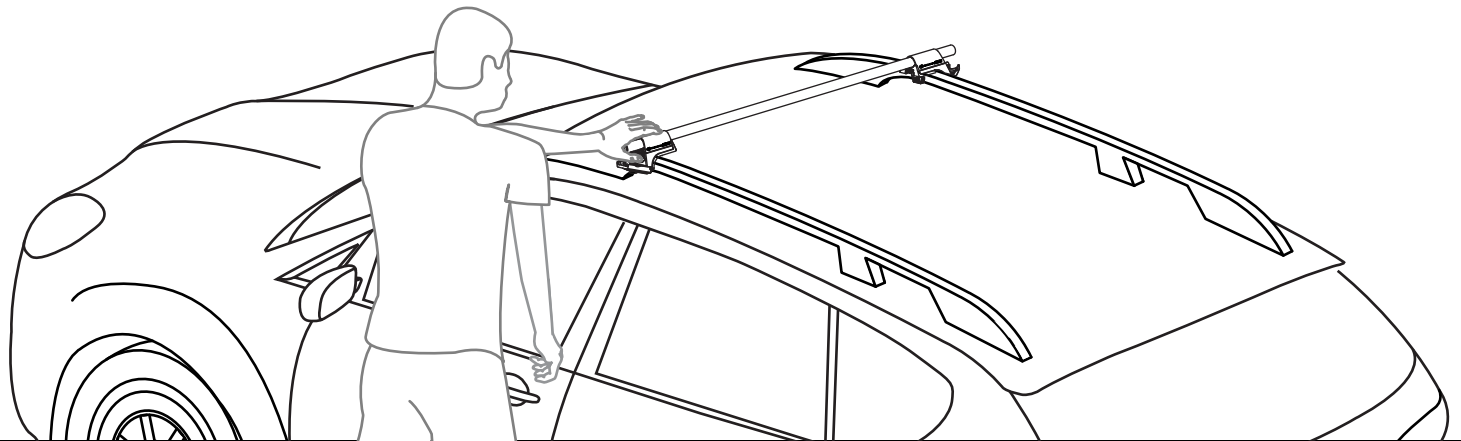
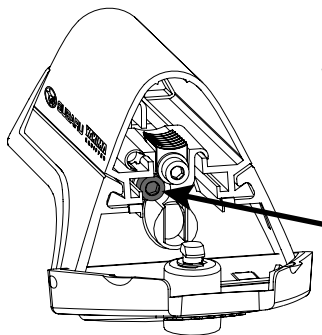
**4 Adjust the claw horizontally.**

With the covers open...

Locate the black claw tightener.

Complete claw adjustment by turning the black claw tightener clockwise using the included wrench.

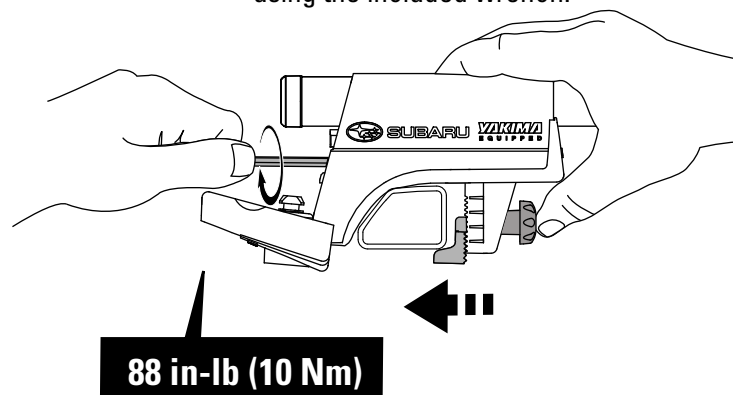

**5 Check your work.**

Did you establish both  
*solid* contact points?

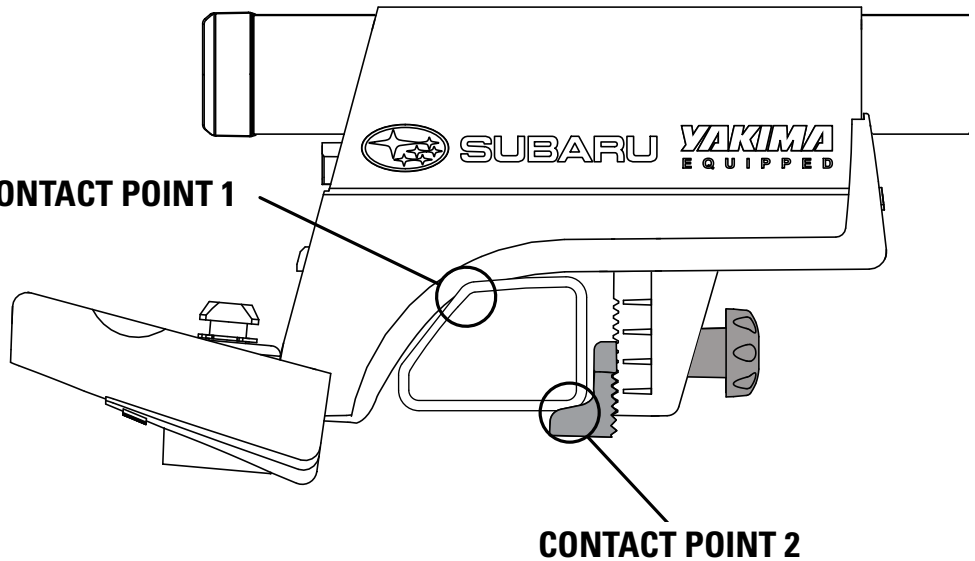
**CONTACT POINT 1****CONTACT POINT 2****6 Center round bar.**

Center the bar so  
that the ends of the  
crossbar protruding  
from the towers  
are set to an equal  
distance.

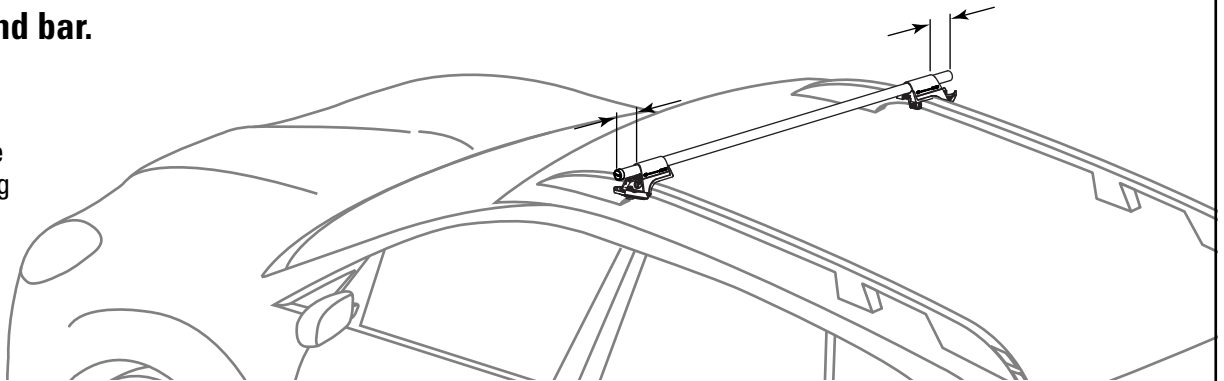
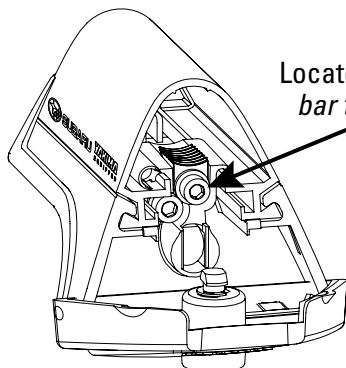
**7 Complete assembly of tower/bar system.**

Locate the silver  
bar tightener.

Assemble bar to tower  
by tightening silver bar  
screw using integrated  
assembly device.

Verify that towers are  
secure. If movement  
occurs, retighten towers.

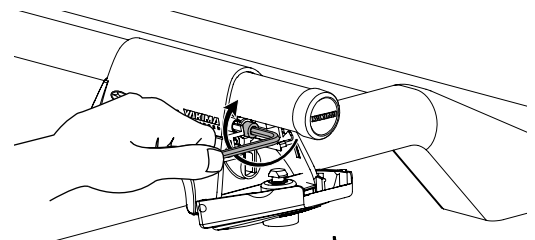

**Be sure to tighten  
both towers!**

**88 in-lb (10 Nm)**



**SUBARU**

PART NUMBER: E361SXA600

**INSTALLATION  
INSTRUCTIONS**

**DESCRIPTION: TRIBECA CROSSBAR KIT**

**8 Check your work.**

**CHECK THE INSTALLATION!**  
*Grip the crossbar inboard to towers;  
push and pull using only arm strength.*

*The vehicle should rock back and forth,  
but the towers should not budge.*

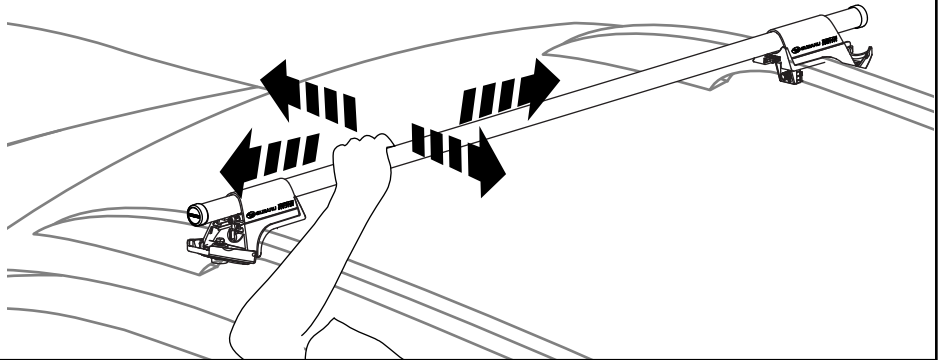

**9 Install second set of towers and crossbar.**

Now simply follow the instructions from the beginning to install your second set of towers. Position rear towers an equal distance from front towers. Be sure to read all cautions and warning on the next page. Return integrated assembly device to storage location. Close the covers. Lock the towers.

**10 Install air deflector.**

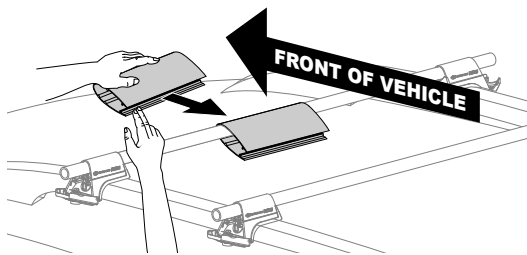

Install air deflector to front  
and rear crossbar.

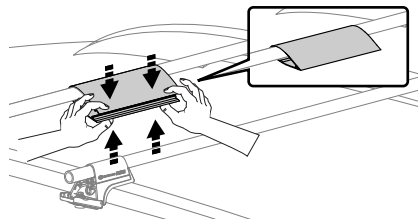

Press edges together to  
close deflectors.

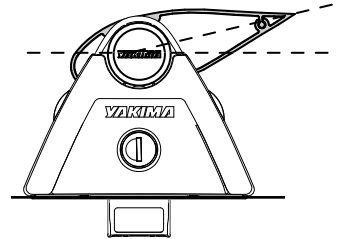

Angle upward slightly.

**NOTICE: THIS CLAMP-ON RACK IS INTENDED FOR USE WITH OTHER GENUINE SUBARU RACK MOUNTED ACCESSORIES, SUCH AS THE BIKE RACK, SKI RACK, KAYAK STACKER, AND ROOF CARGO BASKET. YOU MAY HEAR AN INCREASED LEVEL OF WIND NOISE OR WIND RUSH SOUND AS A RESULT OF INSTALLING THIS RACK ON YOUR VEHICLE. IF THE NOISE LEVEL IS OBJECTIONABLE, THE RACK BARS SHOULD BE MOVED REARWARD ON THE VEHICLE OR REMOVED AND INSTALLED ONLY WHEN UTILIZED TO TRANSPORT SOMETHING.**

**REMOVING THE RACKS**

1. Mark tower location with marker or tape.
2. Unlock towers and open covers.
3. Loosen claws (claw tightener).
4. Lift rack up and off (do not disassemble).

**INSTALLING RACKS AGAIN**

1. Open covers.
2. Clean rails and place towers at marked positions.
3. Make sure towers are seated properly, then tighten claws (using claw tightener) close covers and lock.

**PERFORM SAFETY CHECKS ON ALL TOWERS!**



**SUBARU**

PART NUMBER: E361SXA600

**INSTALLATION  
INSTRUCTIONS**

**DESCRIPTION: TRIBECA CROSSBAR KIT**



**WEIGHT LIMITS: MAXIMUM LOAD MUST NOT BE EXCEEDED.**



**THE LOAD LIMIT FOR THIS PRODUCT ON YOUR SUBARU SHOULD NOT EXCEED THE LOAD LIMIT SPECIFIED IN THE VEHICLE OWNER'S MANUAL, EVENLY DISTRIBUTED.**

### REAR GATE

*Some longer loads may prevent the rear gate from fully opening.*

**USE CAUTION WHEN OPENING YOUR REAR GATE.**

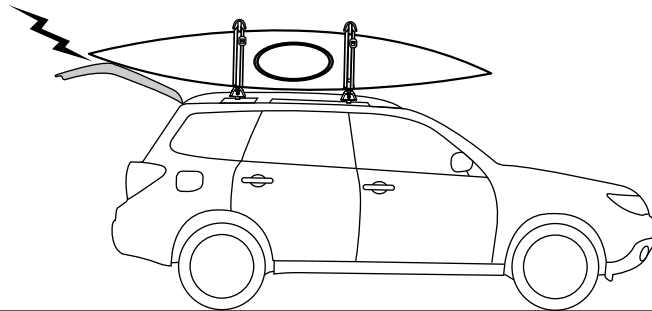

### SUN ROOF

*Sunroof may interfere with crossbars or accessories.*

**USE CAUTION WHEN OPENING SUNROOF.**

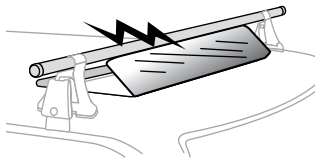

### ANTENNA

Antenna on the roof may need to be removed to prevent interference with the rack or long loads.

### TIE DOWN LONG LOADS

Always tie down both ends of long loads to vehicle. Failure to do so can result in property damage, personal injury, or death.

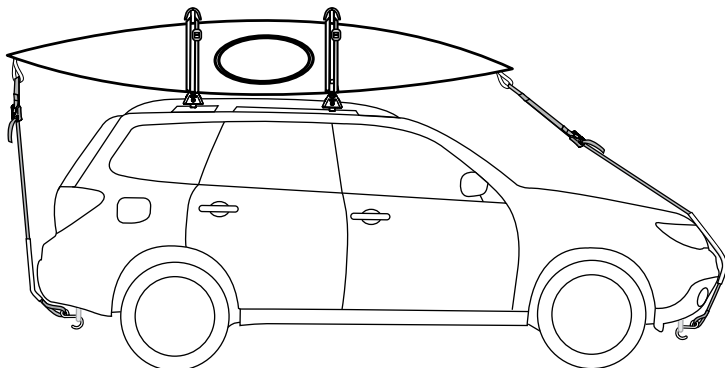

### MAINTENANCE

Use non-water soluble lubricant on screws.  
Use a soft cloth with water and mild detergent to clean plastic parts.

**REMOVE RACKS BEFORE ENTERING AN AUTOMATIC CAR WASH.**

**WARNING: BE SURE ALL HARDWARE IS SECURED ACCORDING TO INSTRUCTIONS. ATTACHMENT HARDWARE CAN LOOSEN OVER TIME. CHECK BEFORE EACH USE, AND TIGHTEN IF NECESSARY.**